

BYO ROUTER SETUP

Fibre to the Building/Node (FTTB/N) Connection

Step 1

Locate the telephone wall socket in your property that has been activated for nbn®. Please note that there may be multiple telephone wall sockets in your property.

Step 2

Disconnect all equipment from your telephone sockets. This includes phones and fax machines plugged in around the property. These devices will interfere with the nbn® signal.

Step 3

Connect your BYO modem to the telephone wall socket using the DSL or VDSL port on the back of the modem and power it on. It is important to use the first (main) socket at your property. If you are unsure of this, you may require a private phone technician to check your wiring.

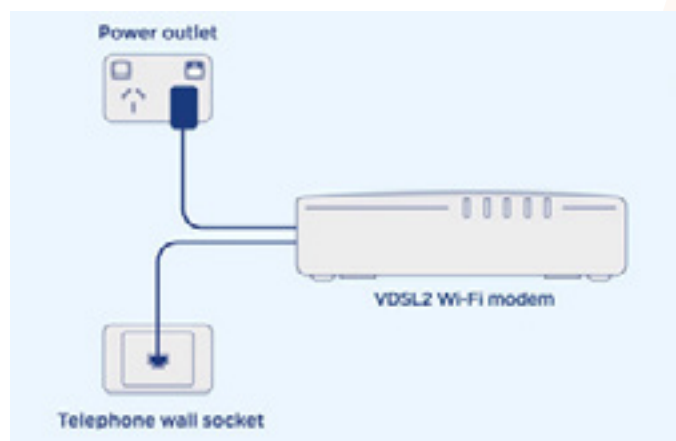

Step 4

After you have connected the modem to the wall socket and powered it up – you should see the DSL light on the modem start to flash. After several minutes this should stop flashing and become steady. This shows you that you have successfully connected the modem to the line that nbn® is active on. If this does not stop flashing, you should try alternative telephone wall sockets in the property until it does.

Step 5

Connect a computer or laptop to your BYO modem via a cable or by Wi-Fi and access the modem configuration page. If you are unsure how to do this, please consult the modem user guide.

Step 6

Most modems will provide a Quick Start Guide or Setup Wizard – please try and follow these steps. Ensure that your modem is configured in VDSL mode and encapsulation is set to PPPoE. On most devices you should leave all other settings as default. Then configure your BYO modem using the ISP username and password that we will have emailed and SMS'd to you.

Due to the number of modem brands available it is hard to give precise setup information here. We recommend consulting your modem user guide or speaking to the manufacturer of your device.

Step 7

After you have successfully configured your BYO modem please wait a couple of minutes for it to connect to the network. After a couple of minutes you should see the authentication light on the modem become lit and steady (not flashing). The authentication light is often labelled 'Internet' or 'www' or 'Web'. Please consult your modem user guide if you are unsure which light is the authentication light.

Troubleshooting

SYMPTOM	THINGS TO TRY
DSL light does not come on or does not stop flashing	<ol style="list-style-type: none"> 1. Try connecting the modem to an alternative telephone wall socket in the property. 2. Try an alternative telephone cord to connect the modem to the wall socket. 3. Ensure that you are connecting the modem via the DSL or VDSL port on the back of the device. If your device does not have a DSL or VDSL port, please consult your modem user guide to ensure it supports VDSL connections. 4. Ensure that the modem is configured in VDSL mode.
www or internet light does not come on	<ol style="list-style-type: none"> 1. Ensure that the modem has been correctly configured with the ISP username and password. Triple check for any spelling mistakes or typos. 2. Ensure that the modem is configured in VDSL mode.
Internet dropouts	<ol style="list-style-type: none"> 1. Check that all other devices are disconnected from the telephone sockets inside the property. This includes phones, fax machines, filters, splitters, extension cords and ensure the modem is connected directly to the first (main) telephone wall socket in the property. 2. If you have auxiliary telephone sockets in the house, you may wish to engage a ACMA certified technician to disconnect your auxiliary sockets and optimise your in house cabling for VDSL.

Technical Support

If you require assistance setting up your BYO device our team is available.

7AM – 12AM WEEKDAYS

8AM – 8PM SAT & SUNDAY AET

Phone: 1800 211 112

Live Chat: www.tangerinetelecom.com.au/chat

Whatsapp: +61 429637422

Overseas: +61 3 9021 9632