



EERO 7

QUICK START GUIDE



eero

This guide provides instructions for setting up, connecting, and configuring your eero 7.

CONTENTS:

Get to know your device	3
How to set up your device	5
How to connect your smart home devices to your network	8
How to create custom settings for people on your network	8
Other important information	9
Need support?	10

GET TO KNOW YOUR DEVICE

The eero 7 provides premium Wi-Fi 7 performance and speeds up to 2.3Gbps on a wired connection or 1.8Gbps on a wireless connection (if you have an internet plan capable of supporting this speed),* all without the premium price tag. The eero 7 features include:

- Whole-home Wi-Fi 7 coverage up to 190 square metres per eero 7.
- Smart technology to reduce drop-offs and provide fast, reliable Wi-Fi.
- Entertainment-ready Wi-Fi to download 4K content, stream music and play online games in confidence.
- Smart home hub functionality compatible with Zigbee Smart Home Hub, Bluetooth Low Energy 5.0, Alexa, Thread, Matter (controller only) and Amazon Connected Home (account linking required).
- Simple, app controlled and guided set up to connect additional eero devices.
- Supports 120+ connected devices simultaneously.
- Ongoing software updates to help keep your network and data safe and secure.

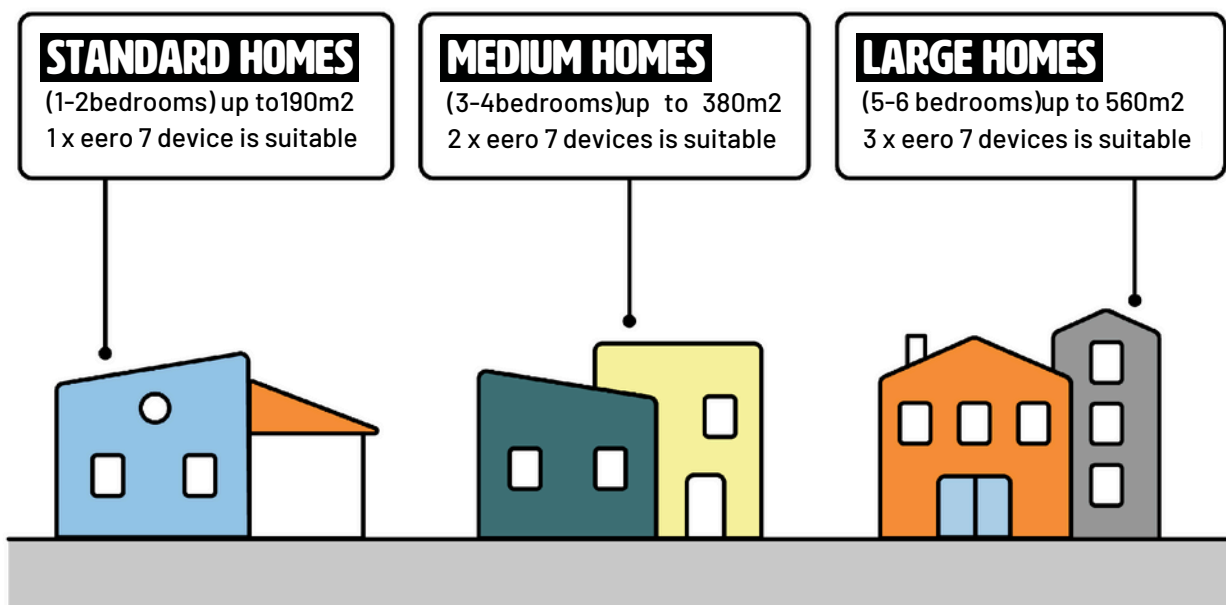

Front view of the device



LED Light

Will indicate connection with a solid blue light.

Back view of the device

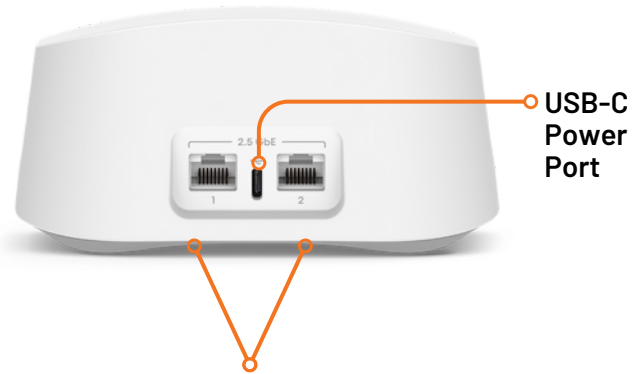









Auto sensing 2.5 gigabit Ethernet Ports

Connect your ethernet based devices, e.g. desktop computer, laptop and/or router.

If your LED is in a different state, including a different colour or is blinking/flashing, please refer to the list below:



LED Colour

What it Means



 No Light	eero doesn't have power
 Blinking White	eero software starting up/connecting to the internet
 Blinking Blue	Broadcasting bluetooth
 Solid Blue	The eero app is connected to your eero and setting it up
 Blinking Green	Multiple eeros detected
 Blinking Yellow	Unapproved USB-C power source used
 Solid White	eero connected to the internet
 Solid Red	eero is not connected to the internet

HOW TO SET UP YOUR DEVICE

Before you start to set up your eero 7 and network you will need the following:

- An iOS or Android device with a data connection.
- The eero app available from the [App Store](#)  or [Google Play Store](#) 
- A router or device with an active connection to a Tangerine internet service.
- An email address.
- An active mobile phone number.

Step 1: Download the eero app and create an account

Download the free eero mobile app from the from the [App Store](#)  or [Google Play Store](#)  and create an account using your mobile number, email address or existing Amazon account.

Step 2: Unplug your nbn[®] connection box

Unplug all devices (including your old router) from your nbn[®] connection box and then unplug your box from power.

Step 3: Connect your eero 7

Using the supplied ethernet cable, connect your eero to your nbn[®] connection box from one of the ethernet ports. How to connect your eero depends on your nbn[®] technology type. If you are unsure what nbn[®] technology type you have, you can check by entering your address in the search bar on our nbn[®] page.

NOTE: If you've recently relocated your Tangerine nbn[®] service, you'll need to delete your existing eero Wi-Fi network before setting up again. Check out our [FAQ](#) for step-by-step instructions on how to delete your network.

Fibre to the Premises (FTTP) & Fixed Wireless

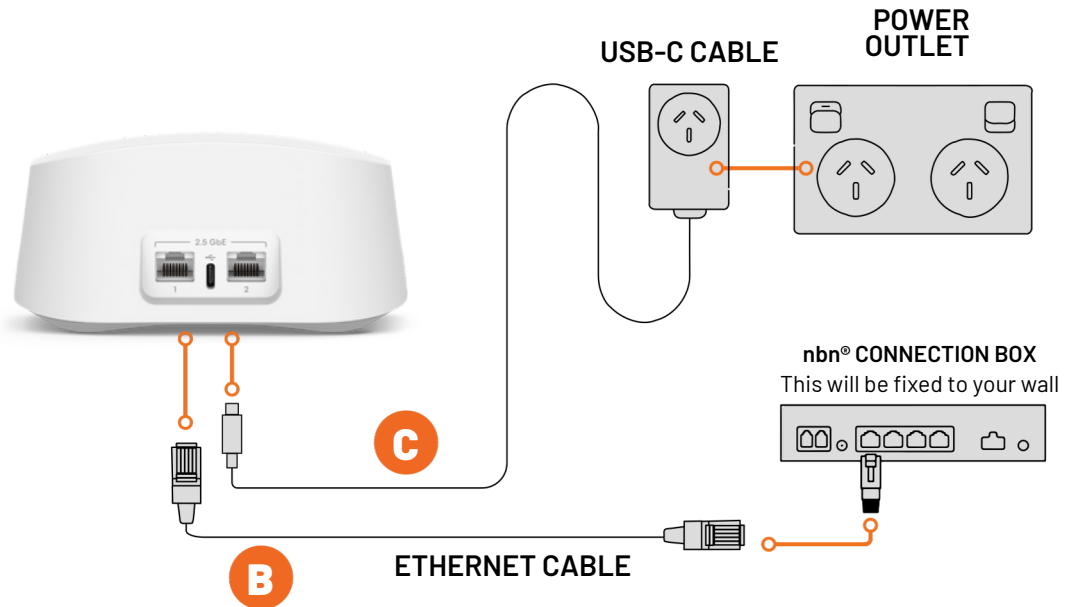

IMPORTANT: Plug your ethernet cable from your eero into your nbn® connection box's active Uni-D port. If you're unsure which port is active, check your nbn® ready to go email from us.

Fibre to the Curb (FTTC) & Hybrid Fibre Coaxial (HFC)

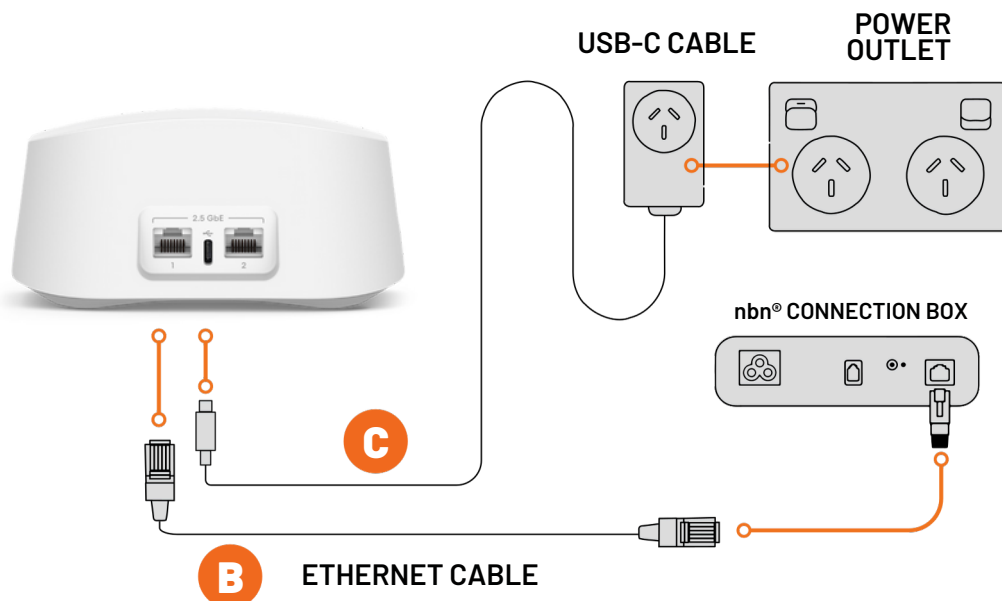

Step 4: Plug your eero 7 to power

Plug your eero and nbn® connection box to an available power outlet. Refer to diagrams above. Make sure you consider the following when placing your eero device in your home:

- Try not to place your eero device inside a media console or cabinet, behind or underneath any large furniture.
- Avoid placing your eero device in front, on top of or under any electronics or appliances as metal objects can block wifi signals.

Step 5: Check your status light and add devices

The status light on your eero will start flashing white as it searches for your device and then turn solid white once it finds it.

Note: If your eero light is in any other state or colour, refer to the table on page 4 or our [FAQ](#).

If you have additional eero devices:

Select the 'Add another eero device' button on your screen and plug your additional eero to power. If you have a third eero device to add to your network, follow the same steps otherwise select the 'Finish setup' button.

Now that your eero network is set up you're free to do all the things you love online like stream music, read, and play video games!

HOW TO CONNECT YOUR SMART HOME DEVICES TO YOUR NETWORK

You can connect your smart home devices to your eero network once you have linked your eero account with your Amazon account. If you didn't link your accounts upon sign up, you can do so by:

- Logging into the eero app.
- Navigate to the Discover tab.
- Select 'Amazon Connected Home.'
- Tap 'Connect to Amazon' and login using your Amazon account.

Once your accounts are linked, your enabled devices will join the network almost instantly when plugged in and stay connected even when you change your network name or password through the Amazon Frustration-Free Setup.

HOW TO CREATE CUSTOM SETTINGS FOR PEOPLE ON YOUR NETWORK

You can set custom schedules, control internet access, and apply content filters by creating profiles through the eero mobile app.

- Select the 'Home' tab and tap on the + symbol in the top right corner of the screen.
- Select 'Add a Profile' from the pop-up menu.
- Add a profile name.
- Tap 'Connect to Amazon' and login using your Amazon account.
- Tap 'Done'.

How to customise profile settings:

- Select the 'Home' tab and tap the profile or device for which you want to set a schedule.
- Select 'Add a Scheduled Pause'.
- Update the schedule name, start time, end time, and frequency for the scheduled pause, then tap 'Save'.

OTHER IMPORTANT INFORMATION

1 Year Manufacturer's Warranty

In addition to any rights or remedies you may have under the Australian Consumer Law, your eero device also comes with a 1-year limited manufacturer's warranty from the date of purchase that covers faults with eero devices purchased from Tangerine (subject to certain exclusions). Please see our Hardware Warranty Information for further information, including how you can contact us to submit a warranty claim.

eero Secure Subscription at no additional cost

When you purchase an eero device from Tangerine, we will provide you with an ongoing subscription to eero Secure at no additional cost for use with a compatible Tangerine internet service.*

eero Secure protects your growing online life by helping to keep your family's personal information, connected devices, and network protected from online threats. eero Secure also gives you access to advanced parental controls, including content filters and the ability to block and allow individual sites to help keep your family safe from the content they're not ready for.

*eero Secure subscriptions are subject to Tangerine's Standard Form of Agreement – Part I and other applicable policies available on our [Policies page](#).

The features of eero Secure include (subject to change from time to time on provision of reasonable notice):

Feature	Description
eero Internet Backup	Connect your eero network to an alternate internet data hotspot to keep the network up and running during an outage.
Advanced Security	Advanced protection against online threats for all the devices on your network.
Block Ads	Block ads to remove ads from websites and applications.
Block / Allow websites	Block access to individual websites and apps. Allow access to individual sites and apps that may otherwise be blocked by content filters.
Block apps	Block popular apps by profile.
SafeSearch	Feel rest assured that Google search results are appropriate using SafeSearch.
Content Filtering	Use Content Filtering to set profile-specific filters against different types of content.
Network Insights	See your historical network usage and eero performance data over time.

NEED SUPPORT?

For further information on the eero 7 please refer to our [website](#).
Alternatively, for Customer Service and troubleshooting, contact our team on **1800 211 112**.